

SERIES FB 20/...

FOR PRECAST CONSTRUCTION AND FAIR FACED IN-SITU CONCRETE

EXPANSION JOINT SYSTEMS

■ **SECURE FIXING AND GOOD WATERTIGHTNESS**
BY PERMANENT ELASTICITY AND SPECIAL DESIGN OF THE SITE BARBS

■ **VERY GOOD SOUND AND THERMAL INSULATION**
BY SPECIAL CELLULAR DESIGN OF THE PROFILES

■ **INTERSECTIONS EASILY POSSIBLE**

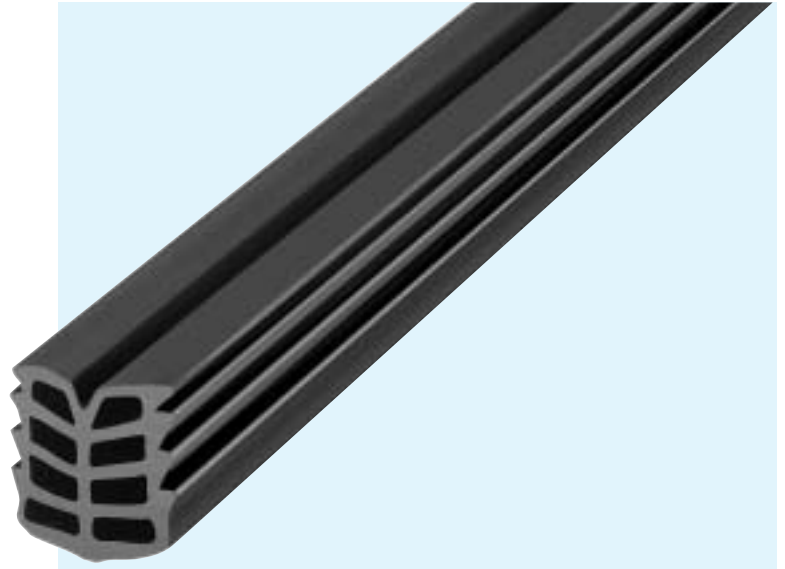

TECHNICAL DATA

Profile	Nominal joint width mm	Depth of joint min. mm	Total movement mm
FB 20/1518	10	25	6
FB 20/1820	12	25	6
FB 20/2122	15	30	7
FB 20/2422	18	30	7
FB 20/3028	20	35	12
FB 20/4030	28	45	14
FB 20/5038	35	55	20
FB 20/6048	45	65	20

MATERIAL

SYNCA-Rubber, long wearing, weather resistant, temperature resistant (-30°C to +120°C), extensively resistant to oils, acids and bitumen. Production length: 20 m, standard colours: black, grey

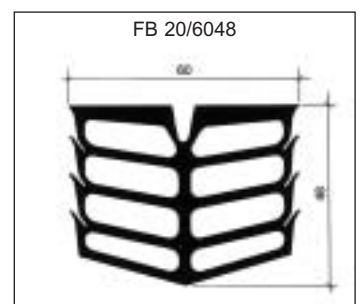
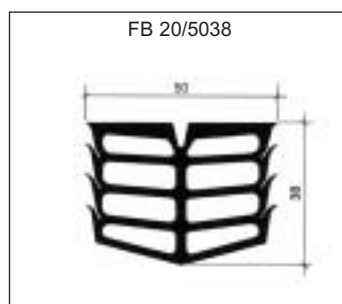
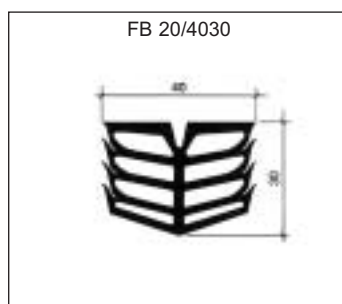
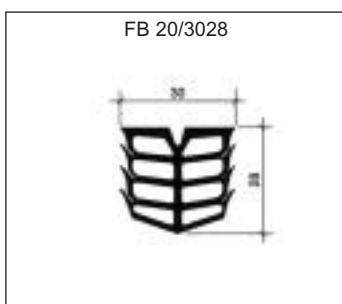
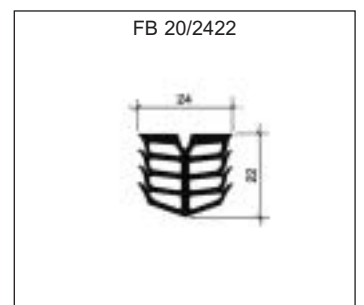
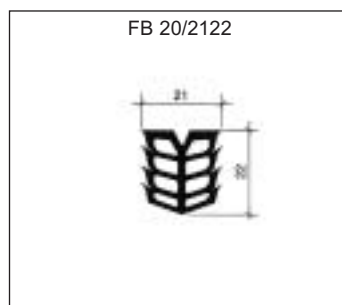
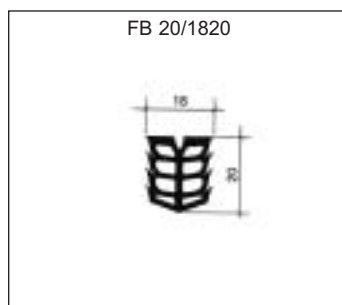
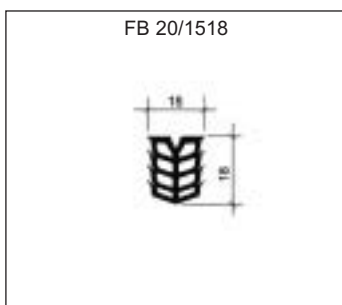
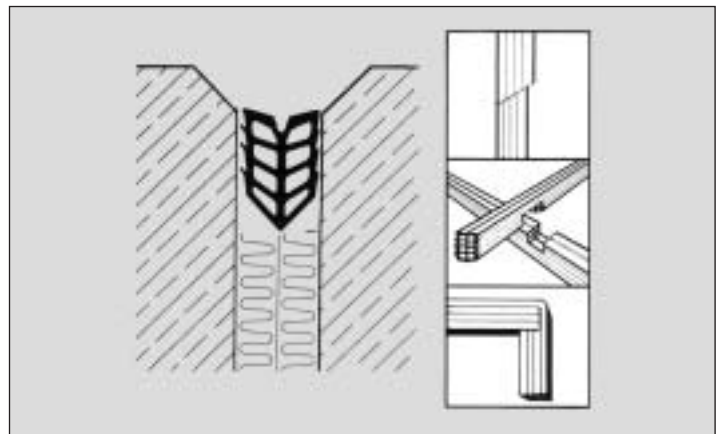

Scale 1 : 2