

19. March 2012

## grate Saturn 145, 145 mm

Product Number: **502292**  
 EAN: 4001636502292  
 Discount group: 3

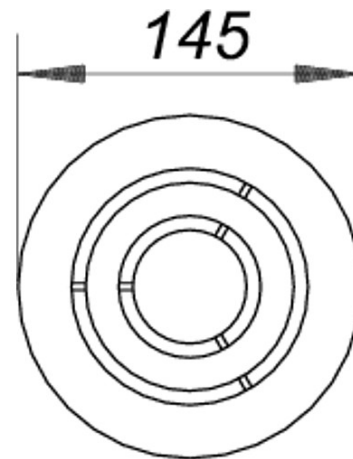

### Specification clause

for 155 frame  
 grate with design ""Saturn"", 5 mm 316Ti stainless steel

Product No.	Description	Dimensions
503039	frame V, S 15/ d: 155	S 15/ d: 155 mm
503091	frame V, S 15/ d: 155, 316Ti	d: 155 mm
500755	frame VER 15, 304, 155 mm	d: 155 mm
500496	RENO-frame, 155 mm	d: 155 mm