

19. March 2012

floor channel CeraLine F 500

Product Number: **520012**
 EAN: 4001636520012
 Discount group: 8

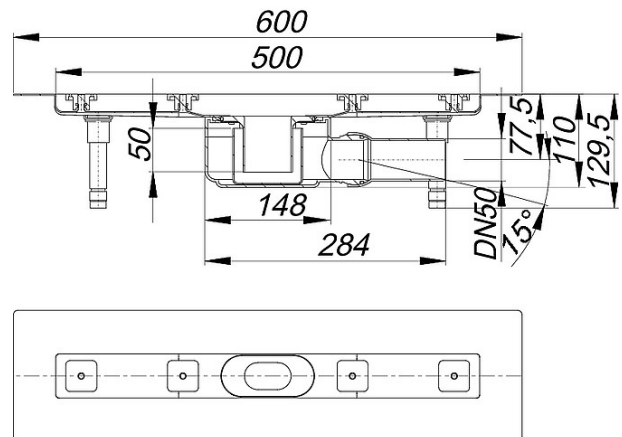

Specification clause

Linear drainage
 outlet: DN 50 ball-joint adjustable
 0 - 15
 with: sound absorbing height
 adjustable levelling legs,
 integral sand coated flange for
 secure bonding of under-tile
 waterproofing, drain body with
 removable trap insert, height
 adjustable screws, temporary
 blanking plate, tiling gauges,
 edge trim jigs
 material channel: 304 stainless steel
 material trap: polypropylen,
 with one floor drain body

Product No.	Description	Dimensions
521019	plug	

Product No.	Description	Dimensions
520616	cover plate CeraLine Design brushed finish 500	500 mm
526182	cover plate CeraLine Design brushed finish 500, lockable	500 mm

19. March 2012

523815	cover plate CeraLine Design matt black 500	500 mm
523716	cover plate CeraLine Design polished 500	500 mm
523419	cover plate CeraLine Glass black 500	500 mm
523211	cover plate CeraLine Glass green 500	500 mm
523310	cover plate CeraLine Glass red 500	500 mm
523518	cover plate CeraLine Glass white 500	500 mm
520715	cover plate CeraLine Individuell 500	500 mm
520517	cover plate CeraLine Standard 500	500 mm
526014	cover plate CeraLine Standard 500, lockable	500 mm
523617	cover plate CeraLine Teak 500	500 mm
520913	natural stone set	
521019	plug	
520869	sound-insulating pad CeraLine, 500 x 250 x 8 mm	500 x 250 mm
520494	stainless steel polish	